

# SEGA™ SERVICE MANUAL

## GENESIS II / MEGA DRIVE II (PAL-B/I/G, RGB)

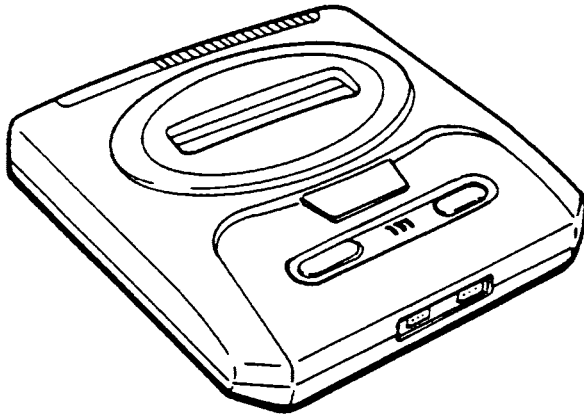

NO.	001-2
ISSUED	DECEMBER, 1993

### SUPPLEMENT (Version 1)

#### CONTENTS

1. DIFFERENCES BETWEEN Ver.0 AND Ver.1.....	2
1-1. Schematic Diagram .....	2
1-2. Difference Table and Parts List .....	3
2. SCHEMATIC DIAGRAM (Version 1) .....	5
3. CIRCUIT BOARD DIAGRAM (Version 1) .....	11
4. PARTS SPECIFICATIONS .....	20

**Sega Enterprises, Ltd.**

# BEFORE USING THIS SERVICE MANUAL

• This service manual includes the MEGA DRIVE II /GENESIS II Ver. 1 data.

## 1. DIFFERENCES BETWEEN Ver.0 AND Ver.1

### 1-1. Schematic Diagram

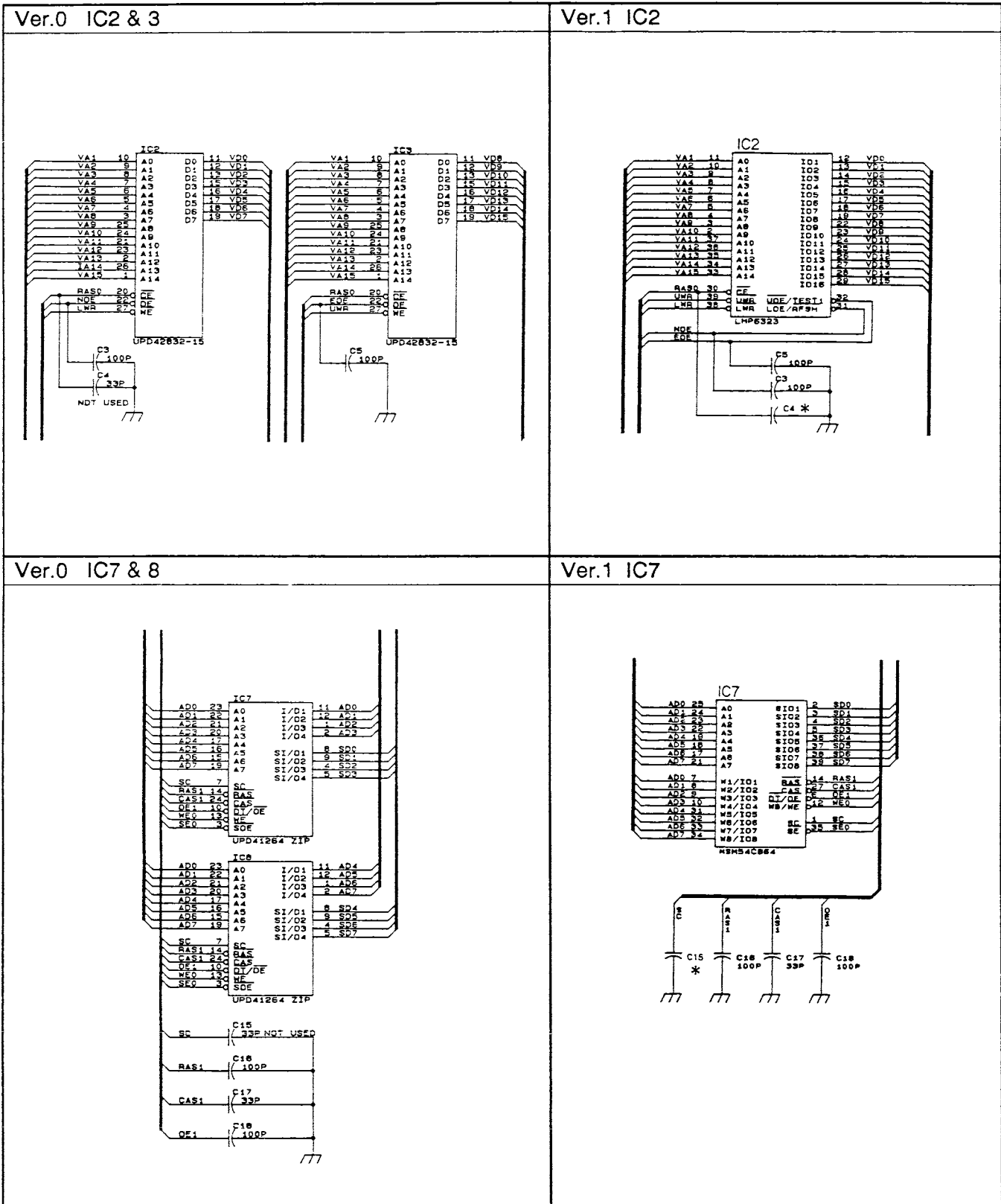

## 1-2. Difference Table and Parts List

Circuit No.	Ver. 0		Ver. 1		Remarks
	Part No.	Description	Part No.	Description	
	837-9602-S 837-9602-SM 837-9602F 837-9603	IC BD MD2 VA0S USA (CBA) IC BD MD2 VA0SM USA (CBA) IC BD MD2 VA0F USA (CBA) IC BD MD2 VA0 EUR (CBA)	837-9793-S 837-9793-SM 837-9793-F 837-9794	IC BD MD2 VA1S USA (CBA) IC BD MD2 VA1SM USA (CBA) IC BD MD2 VA1F USA (CBA) IC BD MD2 VA1 EUR (CBA)	
IC2	315-0547-10A 315-0677-A 315-0759-85A 315-0759-10A 315-0760-12A	IC HM65256BLFP-10 SOP IC TC51832FL-10 SOP IC TC51832AFL-85 SOP IC TC51832AFL-10 SOP IC LH59P832N-12 SOP	315-0810 315-0811 315-0812 315-1819	IC LH5P1632N-15 SOP40P IC LC331632M-12 SOP40P IC HM651632DFP-15 SOP IC TC511632FL-10 SOP	
IC3	315-0547-10A 315-0677-A 315-0759-85A 315-0759-10A 315-0760-12A	IC HM65256BLFP-10 SOP IC TC51832FL-10 SOP IC TC51832AFL-85 SOP IC TC51832AFL-10 SOP IC LH59P832N-12 SOP	NOTHING	NOTHING	
IC7	315-0515 315-0515-15 315-0453 315-0423 315-0481 315-0525 315-0616 315-0622 315-0623 315-5543	IC M5M4C264L-12 ZIP IC M5M4C264L-15 ZIP IC UPD41264V-12 ZIP IC MB81461-12 ZIP IC HM53461ZP-12 ZIP IC TMS4461-12SDL ZIP IC V53C261Z10 ZIP IC KM424C64Z-10 ZIP IC MSM51C262-10ZS ZIP IC KM424C64Z-12 ZIP	315-0795-80 315-0820 315-0850	IC MSM54C864-80JS SOP40P IC KM428C64J-10 SOJ IC HM53861J-8 SOJ	NTSC-F
IC8	315-0515 315-0515-15 315-0453 315-0423 315-0481 315-0525 315-0616 315-0622 315-0623 315-5543	IC M5M4C264L-12 ZIP IC M5M4C264L-15 ZIP IC UPD41264V-12 ZIP IC MB81461-12 ZIP IC HM53461ZP-12 ZIP IC TMS4461-12SDL ZIP IC V53C261Z10 ZIP IC KM424C64Z-10 ZIP IC MSM51C262-10ZS ZIP IC KM424C64Z-12 ZIP	NOTHING	NOTHING	
CE1	150-0418	CAP E 10UF 16V U-TYPE L=5MM	150-0023	CAP E 10UF 16V U-TYPE 20%	
CE33	NOT USED	NOT USED	150-0062	CAP E 47UF 10V U-TYPE	PAL
C11	NOT USED	NOT USED	151-0372	CAP CER CP 33PF 50V KB2125	
C30	151-0309	CAP CER CP 180PF 50V CH2125	151-0354 NOT USED	CAP CER CP 100PF 50V CH2125 NOT USED	PAL NTSC-SM
C61	151-0265	CAP CER CP 0.1UF 25V ZF2125	151-0336	CAP CER CHIP 12PF 50V	PAL
C63	NOTHING	NOTHING	NOT USED	NOT USED	PAL
R42	476-2472-J-10	RES CHIP 4.7kOHM 1/10W 5%	476-2752-J-10	RES CHIP 7.5kOHM 1/10W 5%	
R43	476-2472-J-10	RES CHIP 4.7kOHM 1/10W 5%	476-2752-J-10	RES CHIP 7.5kOHM 1/10W 5%	
R44	476-2472-J-10	RES CHIP 4.7kOHM 1/10W 5%	476-2752-J-10	RES CHIP 7.5kOHM 1/10W 5%	
R45	476-2472-J-10	RES CHIP 4.7kOHM 1/10W 5%	476-2752-J-10	RES CHIP 7.5kOHM 1/10W 5%	
R81	476-2682-J-10	RES CHIP 6.8kOHM 1/10W 5%	476-2472-J-10	RES CHIP 4.7kOHM 1/10W 5%	

## CAUTIONS WHEN REPLACING PARTS

Four ICs shown in the table below are assigned as the service parts for IC6.

No.	Parts No.	Description
1	315-5660	IC CUSTOM CHIP FC1004 REV. YAMAHA
2	315-5660-02	IC CUSTOM CHIP FC1004
3	315-5660-01	IC CUSOTM CHIP FC1004 AMJ
4	315-5708-01	IC CUSTOM CHIP FC1004 AMK

If one of numbers 1-4 is used for IC6, mount C1, C4 and C15 according to the following table.

No.	Parts No.	Description	IC6			
			No.1	No.2	No.3	No.4
C1	151-0316	CAP CER CP 20PF 50V J CH 2125	×	×	○	○
C4	151-0363	CAP CER CP 47PF 50V CH 2125	×	×	×	○
C15	476-2102-J-10	RES CHIP 1kOHM 1/10W 5%	×	×	○	×

× : NOT MOUNTED  
○ : MOUNTED

# 2. SCHEMATIC DIAGRAM (Version 1)

## 2-1. Schematic Diagram-1

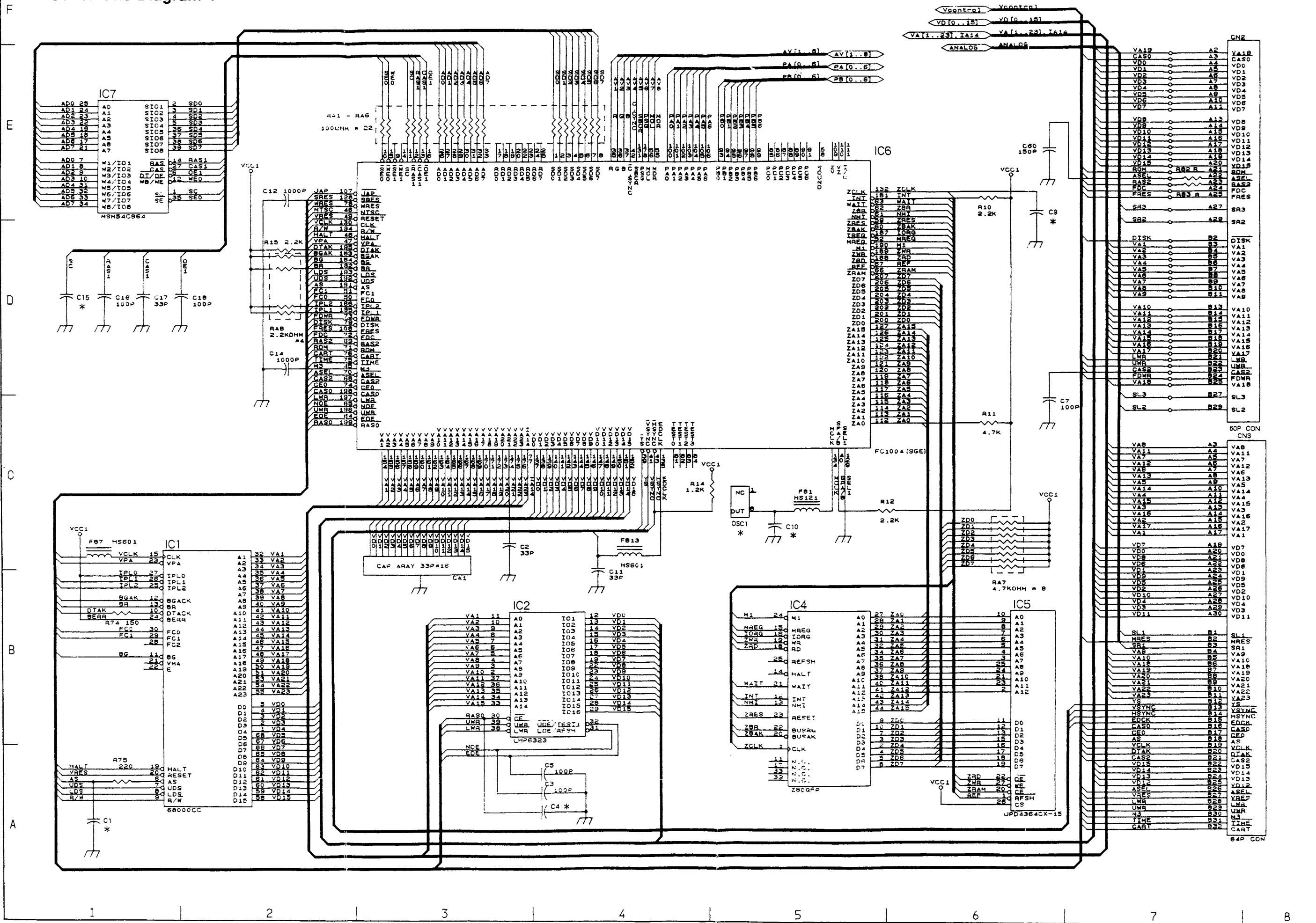

\* Difference Table for Diagram - 1

CIRCUIT No.	GRID	GENESIS II			MEGA DRIVE II
		TYPE-S	TYPE-F	TYPE-SM	
C1	A-1	20pF *1	20pF *1	20pF *1	NOT USED
C4	A-3	47pF *2	47pF *2	47pF *2	NOT USED
C9	D-6	NOT USED	NOT USED	NOT USED	47pF
C10	C-5	NOT USED	NOT USED	NOT USED	10pF
C15	D-1	1K *3	1K *3	1K *3	NOT USED
OSC1	C-5	53.693175MHz			53.203424MHz

Notes:

- \* 1: To be mounted when part No.315-5660-01 or 315-5708-01 is used for IC6.
- \* 2: To be mounted when part No.315-5708-01 is used for IC6.
- \* 3: To be mounted when part No.315-5660-01 is used for IC6.

## 2-2. Schematic Diagram-2

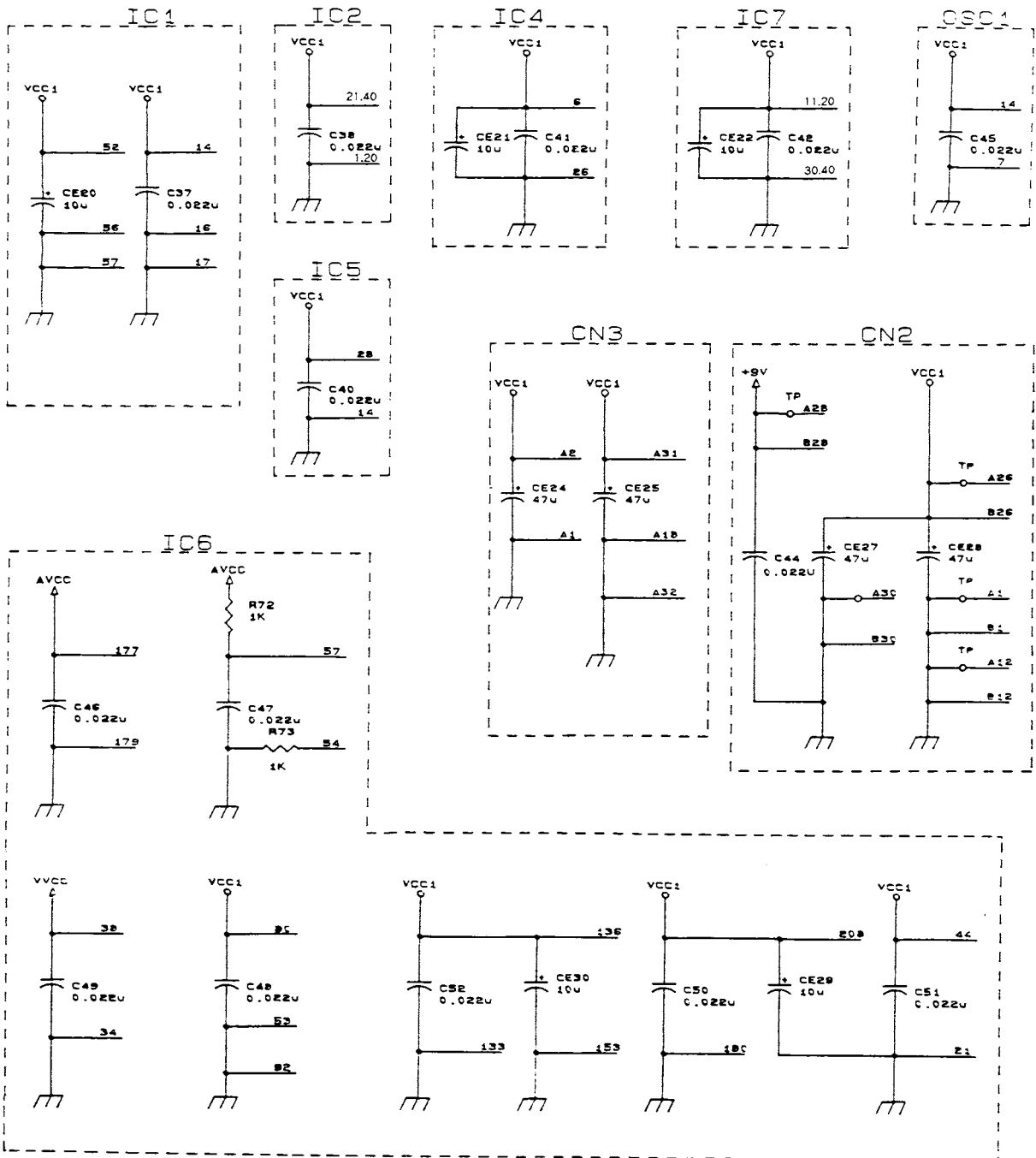

1

2

3

4

### 2-3. Schematic Diagram-3

F  
E  
D  
C  
B  
A

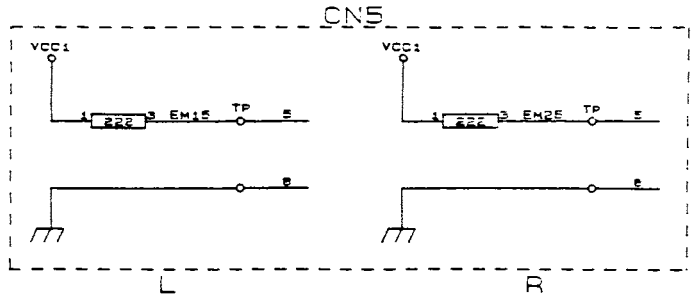
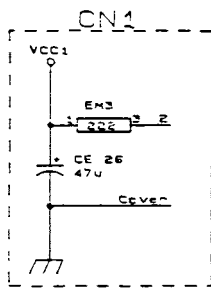
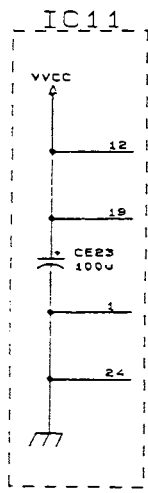

\* Difference Table for Diagram - 4

CIRCUIT No.	GRID	GENESIS II			MEGA DRIVE II
		TYPE-S	TYPE-F	TYPE-SM	
IC11	E-6	CXA1145M	MB3154PF	KA2195D	MB3514PF
C29	D-7	0.01 µ F	0.01 µ F	NOT USED	0.01 µ F
C32	E-6	180pF	15pF	NOT USED	15pF
C57	D-5	NOT USED	100pF	NOT USED	100pF
C62	D-7	NOT USED	NOT USED	NOT USED	12pF
CE14	D-6	10 µ F	220 µ F	10 µ F	220 µ F
R47	E-6	1.2K	12K	NOT USED	12K
R54	D-6	24K	NOT USED	24K	NOT USED
R55	D-6	1K	10K	NOT USED	10K
R57	D-7	330 OHM	330 OHM	NOT USED	1K
R61	E-5	10K	4.7K	10K	4.7K
L2	E-7	100 µ H	100 µ H	NOT USED	100 µ H
L3	D-7	12 µ H	12 µ H	NOT USED	12 µ H
L6	D-7	NOT USED	NOT USED	NOT USED	100 µ H

2-4. Schematic Diagram-4

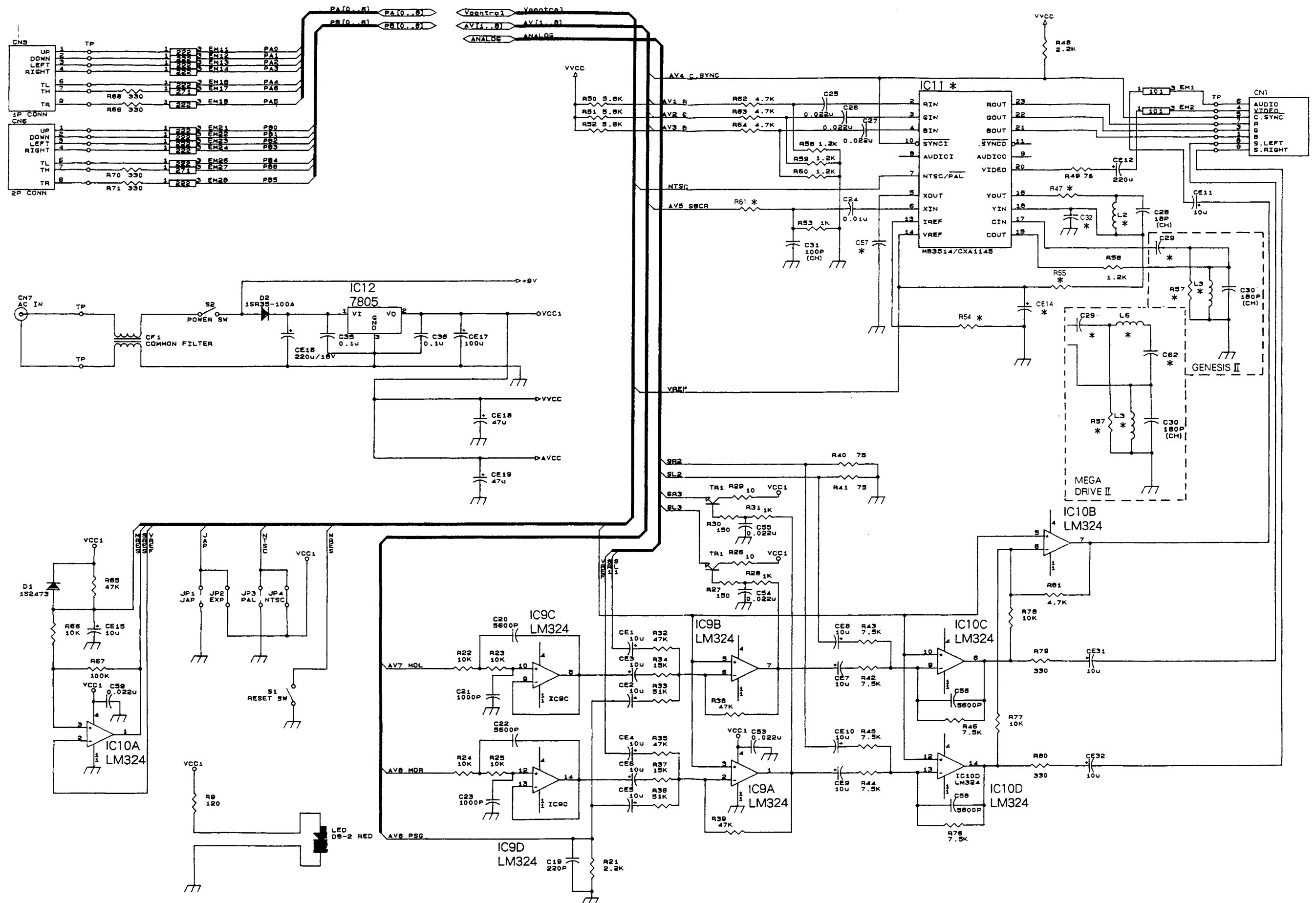

### 3. CIRCUIT BOARD DIAGRAM (Version 1)

3-1. Main Circuit Board (Top View) – For GENESIS II –

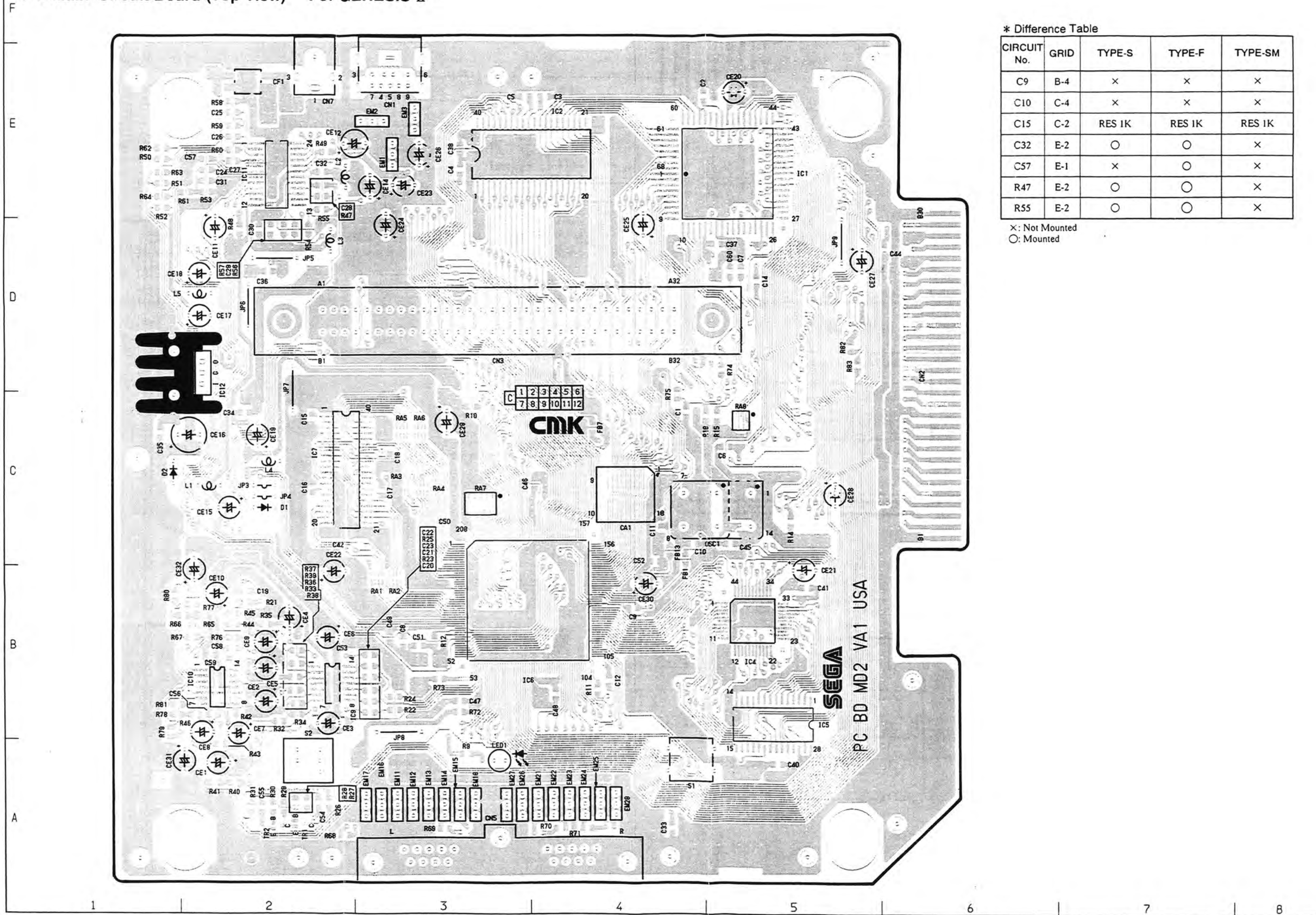

\* Difference Table

CIRCUIT No.	GRID	TYPE-S	TYPE-F	TYPE-SM
C9	B-4	×	×	×
C10	C-4	×	×	×
C15	C-2	RES 1K	RES 1K	RES 1K
C32	E-2	○	○	×
C57	E-1	×	○	×
R47	E-2	○	○	×
R55	E-2	○	○	×

×: Not Mounted  
○: Mounted





3-3. Main Circuit Board (Top View) - For MEGA DRIVE II -

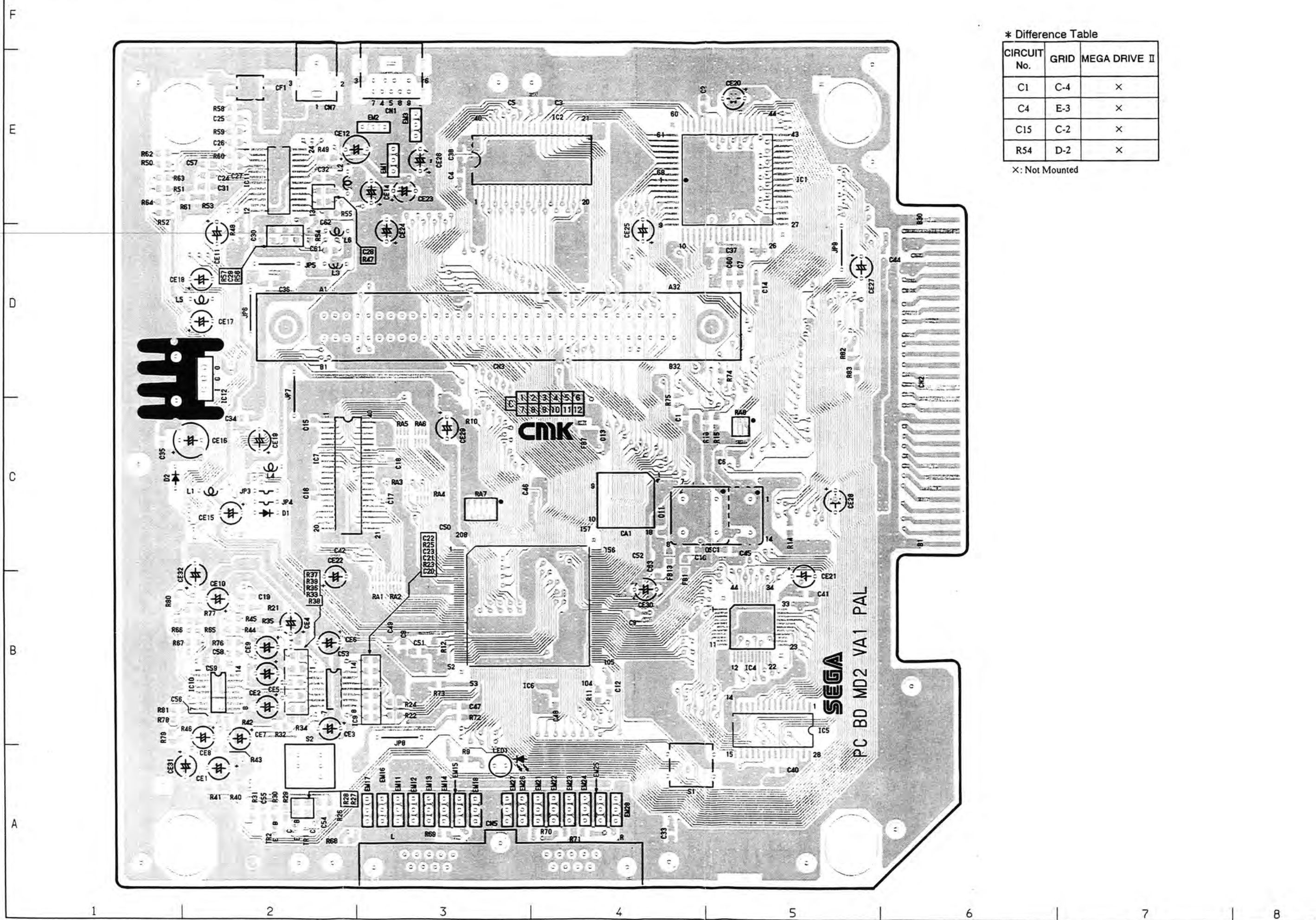

\* Difference Table

CIRCUIT No.	GRID	MEGA DRIVE II
C1	C-4	×
C4	E-3	×
C15	C-2	×
R54	D-2	×

X: Not Mounted

3-4. Main Circuit Board (Bottom View) – For MEGA DRIVE II –

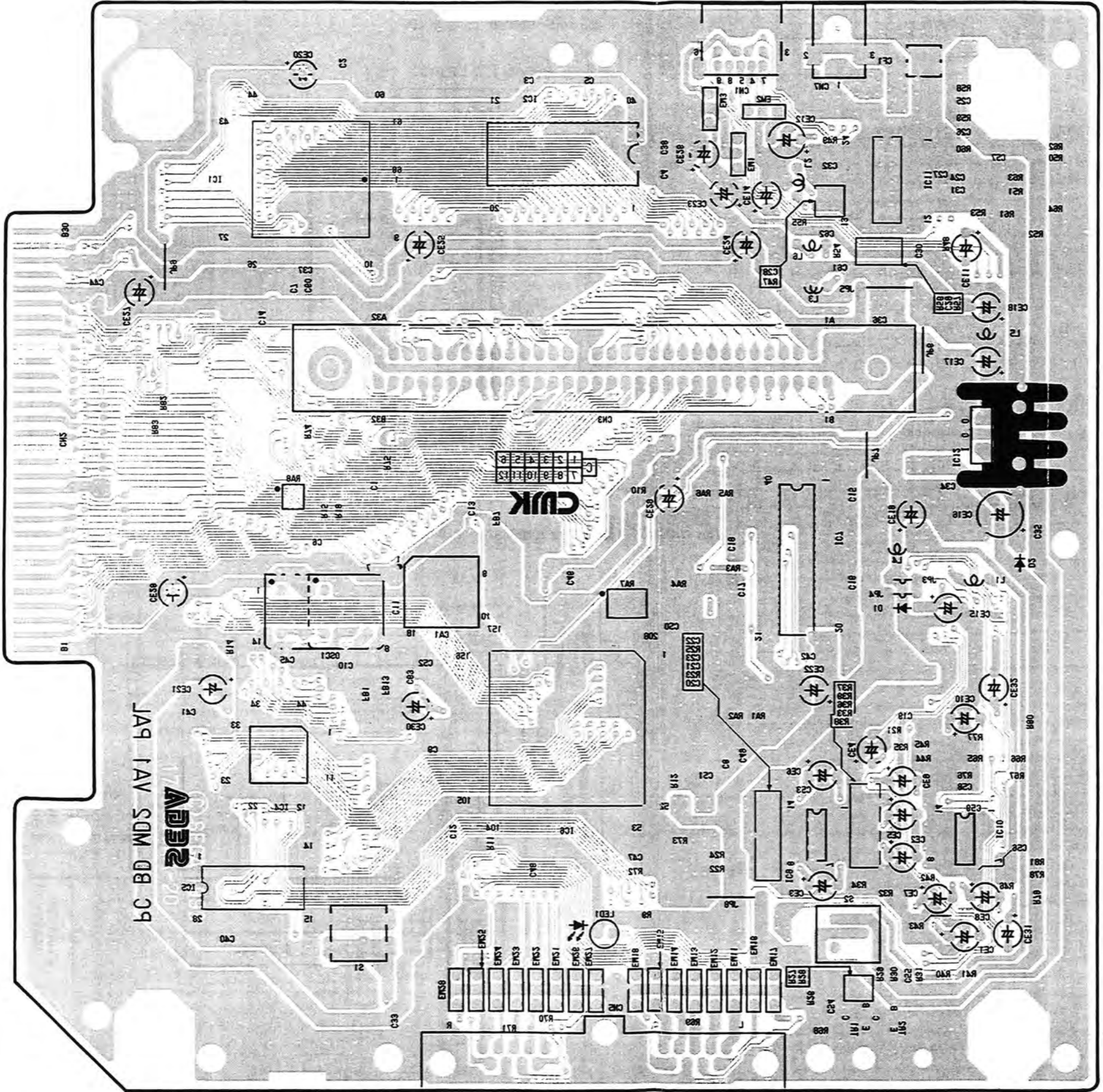

1 2 3 4 5 6 7 8

4. PARTS SPECIFICATIONS

IC2 315 - 0810  
 IC LH5P1632N-15 SOP40P

■ Top View & Pin Layout

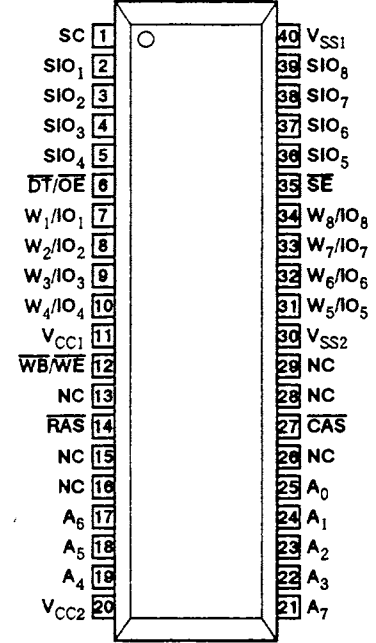

■ Pin Name

Pin Name	Function
A <sub>0</sub> ~A <sub>7</sub>	Address input
$\overline{\text{RAS}}$	Row address strobe
$\overline{\text{CAS}}$	Column address strobe
$\overline{\text{DT/OE}}$	Data transfer/output enable
$\overline{\text{WB/WE}}$	Write bar bit/Write enable
W <sub>1</sub> /IO <sub>1</sub> ~ W <sub>8</sub> /IO <sub>8</sub>	Write mask/data I/O
SC	Serial clock
$\overline{\text{SE}}$	Serial enable
SIO <sub>1</sub> ~SIO <sub>8</sub>	Serial data I/O
V <sub>CC</sub> /V <sub>SS</sub>	Power supply (5V)/ Ground
NC	Not connected

■ Block Diagram

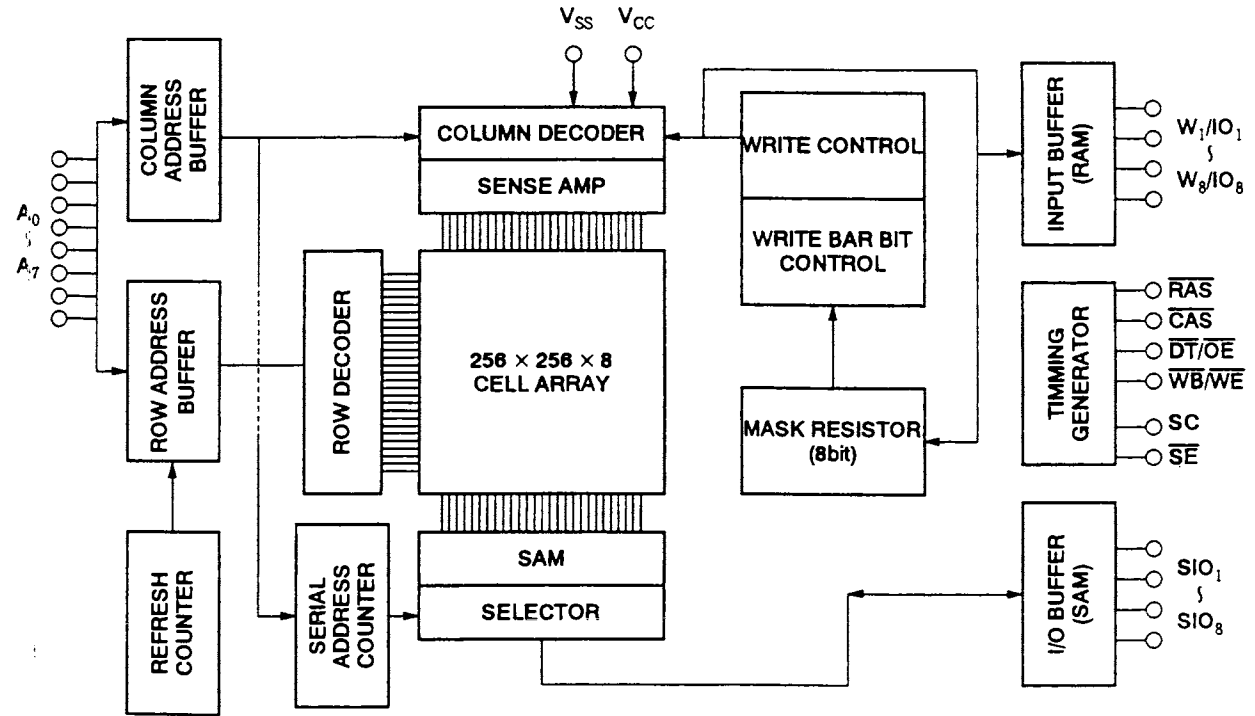

■ Top View & Pin Layout

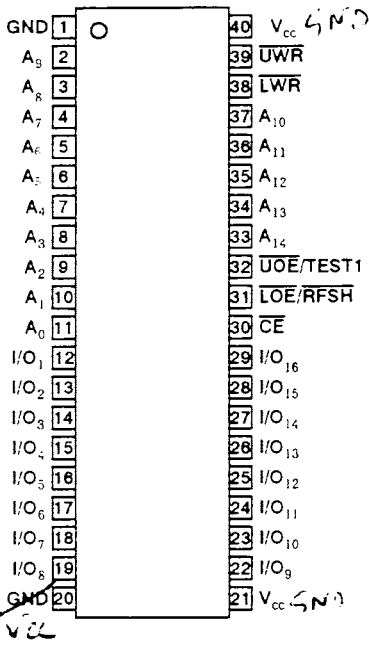

■ Pin name

Pin Name	Function
A <sub>0</sub> -A <sub>14</sub>	Address input
$\overline{UWR}/UWR$	Write enable
$\overline{LOE}/RFSH, \overline{UOE}$	Output enable/refresh input
$\overline{CE}$	Chip enable input
I/O <sub>1</sub> -I/O <sub>16</sub>	Data input/output
V <sub>cc</sub>	Power supply
GND	Ground

■ Block Diagram

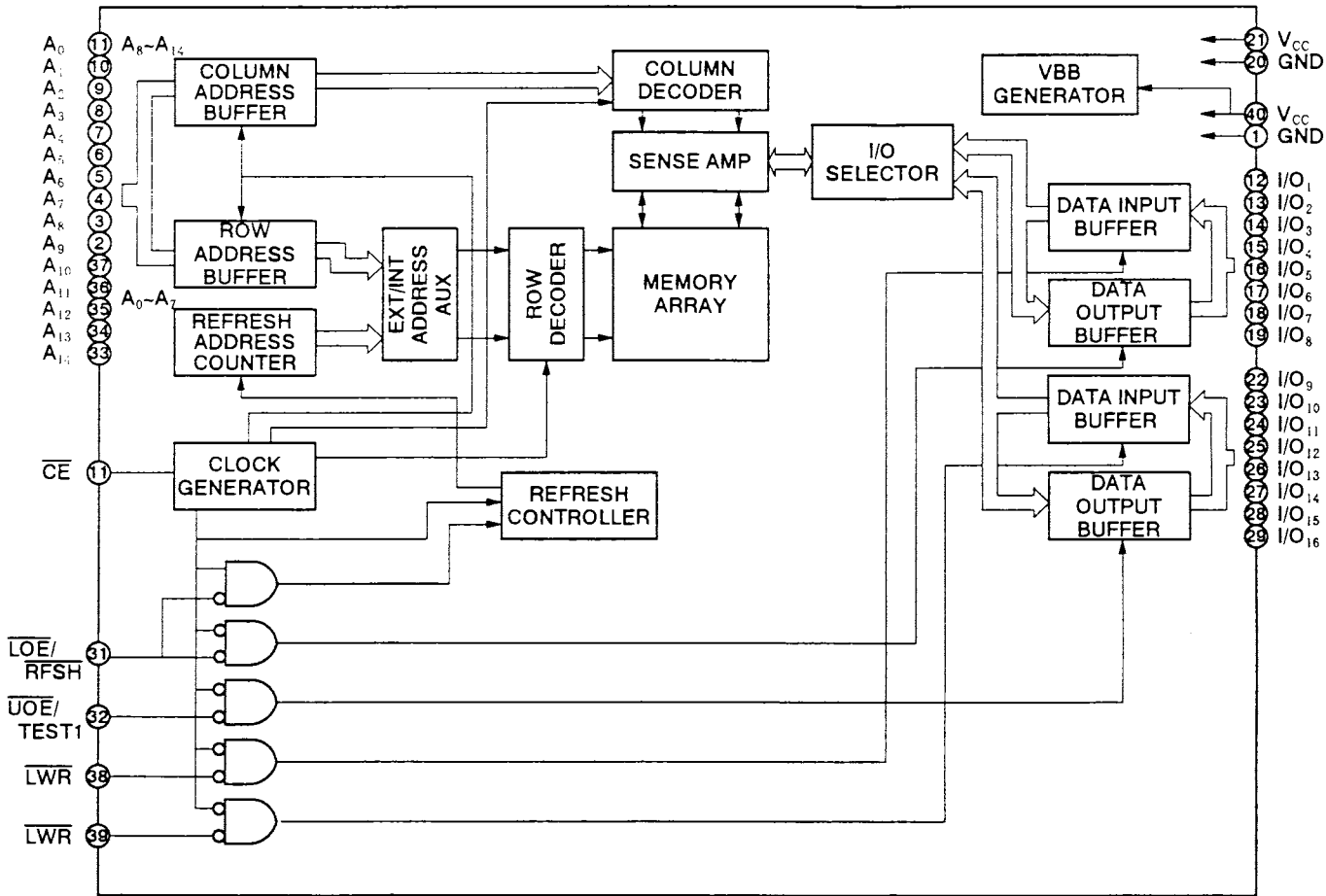

**SEGA™**